

## LARGE DRUM CAPACITY



## ADDITIONAL EQUIPMENT & SERVICES

- Electric / pneumatic control valve with manual lever and including 7m wanderlead control, heavy duty 16 amp socket, electrical control system with all wiring in Armaflex protection also includes dump valve with emergency stop button ensuring compliance with EU machinery directive.
- Wire Rope – up to 50m x 12mm dia. (1960N/mm<sup>2</sup> grade) fully galvanised flexible, crush resistant with heavy duty safety hook.
- Hydraulic oil reservoir tank with filter sight gauge and filler cap.
- Radio control unit to give flexibility in operating the winch up to 40m distance.
- PTO and pump.
- Diesel or petrol donkey engine power packs.
- Snatch blocks.
- Full or partial fitting can be provided, including load testing and certification

## RAMSEY BH550 5 Tonne Hydraulic Winch

### Heavy Plant Moving & Recovery, Rigid Vehicles, Semi-Trailers

The Ramsey BH550 has set itself apart from the competition by becoming the most popular heavy duty winch with all major plant hire companies.

It can be mounted partially into or above floor level and has the ability to withstand sudden shock loading - often associated with this type of work. Featuring a large diameter drum with deep flanges, this robust machine requires very little maintenance. Fully compliant with EN 14492-1 regulations.

### FEATURES INCLUDE

- **5080kgf line pull**  
Rated line pull of 49.8kN
- **EN 14492-1 compliant**
- **Heavy duty worm drive**  
Built to take shock loading
- **Hydraulic motor and mounting angles**  
Supplied with the winch
- **Wedge pocket rope anchor on drum**  
Major safety benefit - prevents rope release from drum fixing
- **Excellent rope storage**  
Up to a maximum 50m x 12mm (1960N/mm<sup>2</sup> grade) rope, 6 x 36 wire core construction for maximum flexibility
- **Fairlead roller guides**  
Heavy duty with greaseways
- **After sales service**  
Technical advice given on winch fitting and component replacement, plus efficient overnight parts despatch and fast repairs. Factory winch installation available

### SECURE WIRE ROPE ANCHORAGE

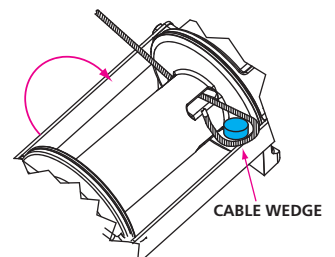

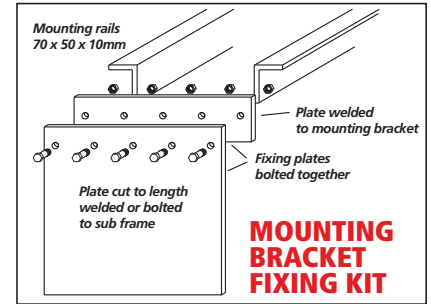
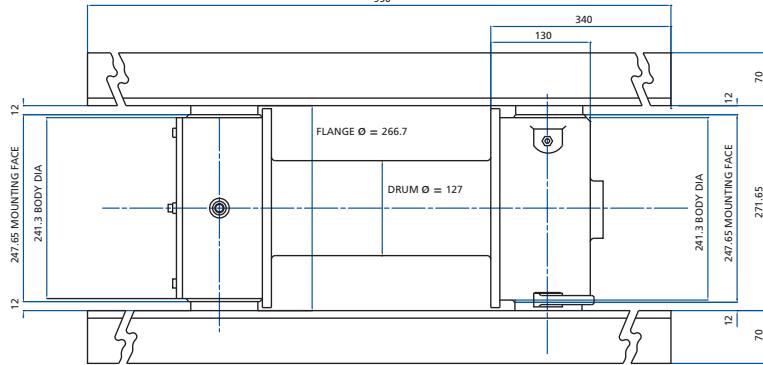
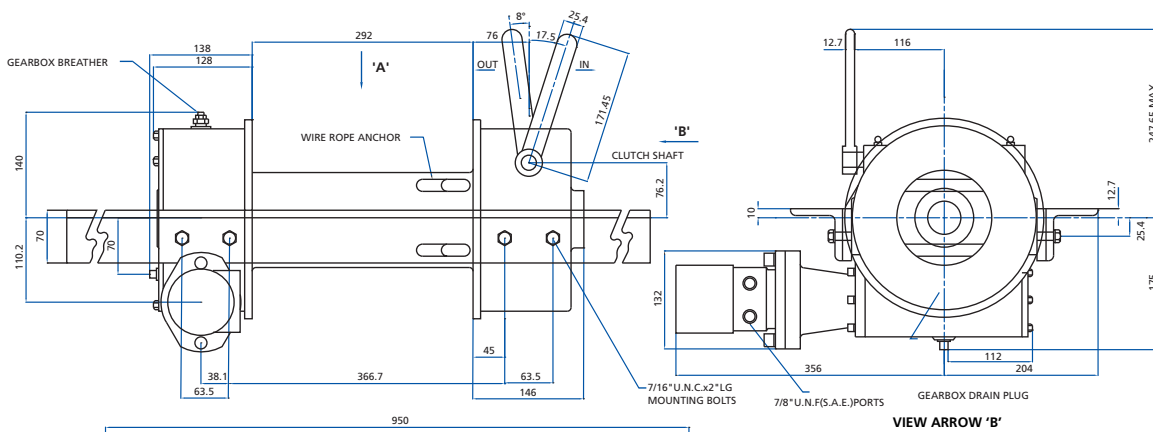

## HYDRAULIC PERFORMANCE

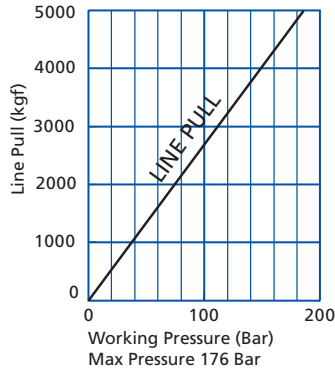
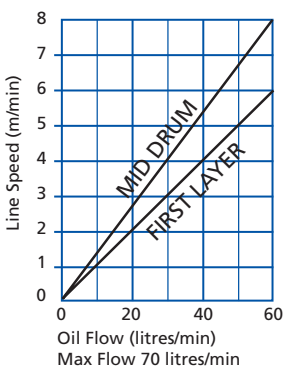

BH550 is supplied with mounting angles. A mounting bracket fixing kit is also available as an optional extra.

	kN	LAYER			
		1	2	3	4
Maximum Rated Line Pull by Layer	kgf	49.1	42.2	37	32.3
BH550 Rope Capacity Cumulative by Layer (12mm Dia. Wire Rope)	m	5000	4300	3770	3300
*Line Speed at 50 l/min	m/min	7.2	17.8	29.7	42.7
		5	5.7	6.5	7.3

\* Based on recommended 12mm wire rope, 1960N/mm<sup>2</sup> grade and 102cc / rev. motor.

## INSTALLATION

The winch is supplied complete with the mounting angles as illustrated. These must be cut to length to suit the installation and the ends bridged with 12mm steel plates. These plates are then bolted through the securing framework on the vehicle. This method of installation ensures the winch can be removed for maintenance purposes if required. A fitting kit including the end plates and longitudinal chassis mounting plates are available as an optional extra see diagram above right.

## SPECIFICATIONS

- Rated Line Pull: 49.8 kN (5080kgf). EN 14492-1 compliant
- Line Speed: 5 m/min at 50 lt/min. on 1st layer, up to 7.3 m/min. on 4th layer
- Wire Rope: 12mm diameter x 50m length (1960N/mm<sup>2</sup> grade. 6 x 36 wire core construction recommended)
- Weight: Weight of winch only: 68kg. Including roller guides, mounting bracket and wire rope: 100kg
- Gear Reduction: 40:1
- Gear Type: Worm with phosphor bronze heavy duty wheel providing self braking, running in oil bath
- Winch Construction: Aluminium cast housings with steel drum
- Motor: Hydraulic – can be provided to match pressure and flow available to give best performance characteristics
- Drum: 127mm dia. x 292mm length with wedge pocket rope anchor. Flange diameter 267mm
- Roller Guides: Extra heavy duty with greaseways

## NOTES

These winches must not be used for the movement of personnel and 5 wraps of wire rope must be maintained on the drum.

Data shown is approximate and intended as a guide only.

## WARRANTY

Each new winch is guaranteed against defects in workmanship and material defects for a period of twelve months from date of purchase.

Wire ropes are not included under warranty.

**Bushey Hall Winchmaster** sales@bhwwgroup.co.uk www.bhwwgroup.com

**Southern Office:** Lismirrane Industrial Park, Elstree Road, Elstree, Herts, WD6 3EE Tel: +44 (0)20 8953 6050 Fax: +44 (0)20 8207 5308

**Northern Office:** 6 South Orbital Trading Park, Hedon Road, Hull, East Yorkshire, HU9 1NJ Tel: +44 (0)1482 223 663 Fax: +44 (0)1482 218 285

Bushey Hall Winchmaster is a division of BHW Group Limited. Registered in England No. 1342461



CERT. No. 1769

BH15/10.10.11